

The NATIONAL TIME Addressable Analog Thermal detector utilizes state of the art electronic temperature sense to provide fast and accurate temperature monitoring. The thermal detector is capable of monitoring temperatures in the range of 75°F to 155°F. The powerful DigiComm™ communication protocol enables reliable and accurate information to be exchanged between the detector and the Fire Alarm Control Panel. The thermal detectors feature programmable status LED indicators. The detector address is set in its base, allowing a convenient and trouble free maintenance procedure. The detector mounts to a selection of base styles to accommodate installation requirements.



Features:

- Electronic Temperature Sensing
- Style 4, 6, or 7 Communication Wiring
- Superior DigiComm™ Digital Communication Protocol
- Attractive Packaging
- LED Indicator
- U.L. Listed

Mounting Diagrams

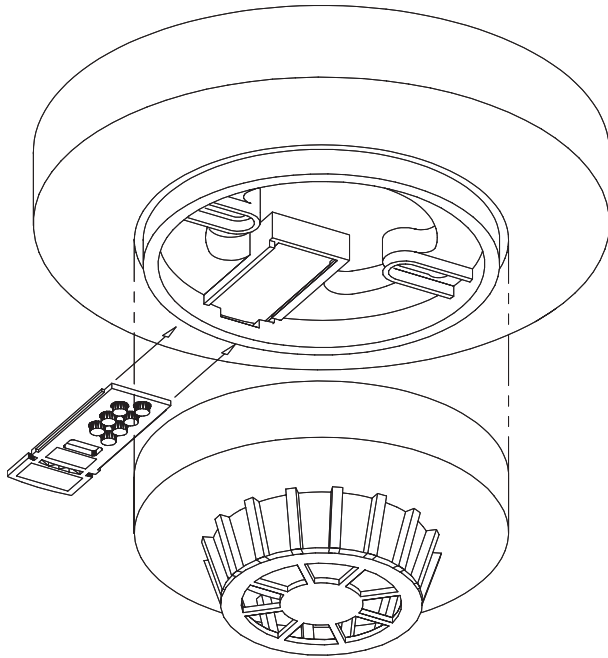

Shown with D900-BASE6 and D900-IDENT

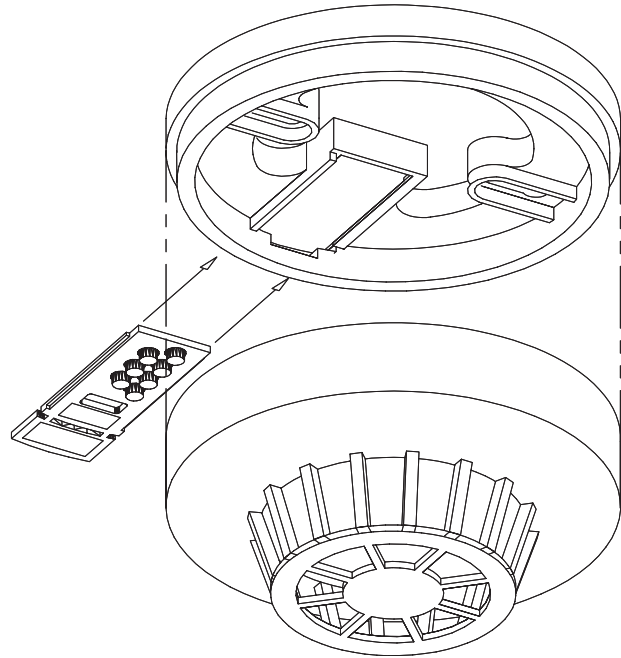

Shown with D900-BASE4 and D900-IDENT

Specifications

DIGICOMM™ LOOP POWER: Voltage Range 17VDC to 28VDC
Alarm and Supervisory Current 250uA (LED Active 3mA)

(Note: add 4mA of Alarm current if using D900-BASE6 SOUND or D900-BASE6 AUX)

COMMUNICATION: Style 4, 6, or 7 (via DigiComm™ Communication Loop)

ALARM TEMPERATURE: 135° F

MONITOR TEMP. RANGE: 75°F to 155°F

FINISH: White Polycarbonate

DIMENSIONS: 4" dia. x 1.65"

NET WT.: 2.1 oz.

MOUNTING: To DigiComm™ Isolator Base (see Bulletin F-360)

SPACING: 50' x 50' at 10' Ceiling Ht.

Ordering Information

Part No.	Description
D900-TEMP	Digicom™ Thermal Detector

Note: Bases and D900-IDENT are ordered separately (see Bulletin F-360)